



Opticks:



Optical Instruments
from Ancient Times to the Present

OLLI-OP

Experiments

OLLI-OP Optical Bench Kit

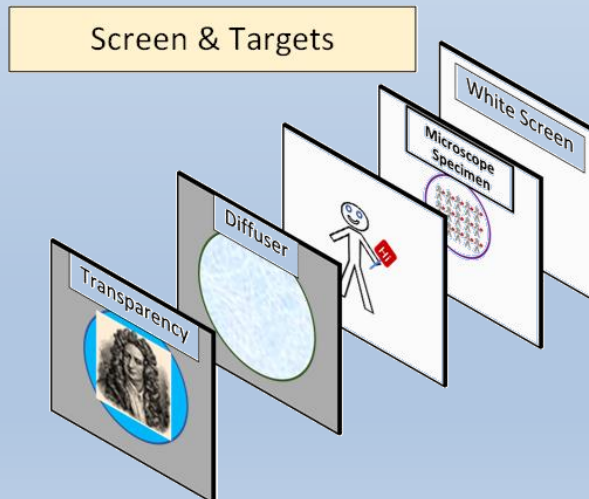
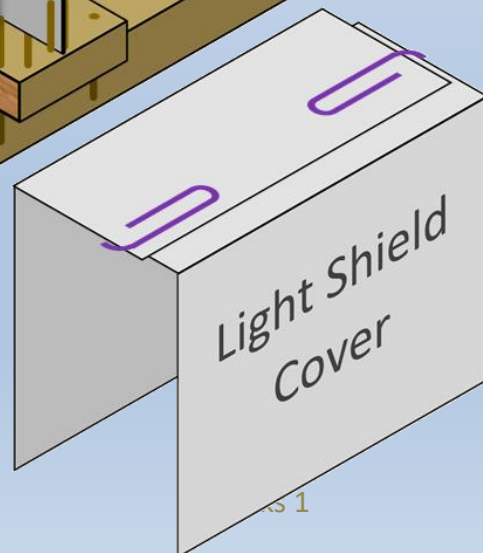
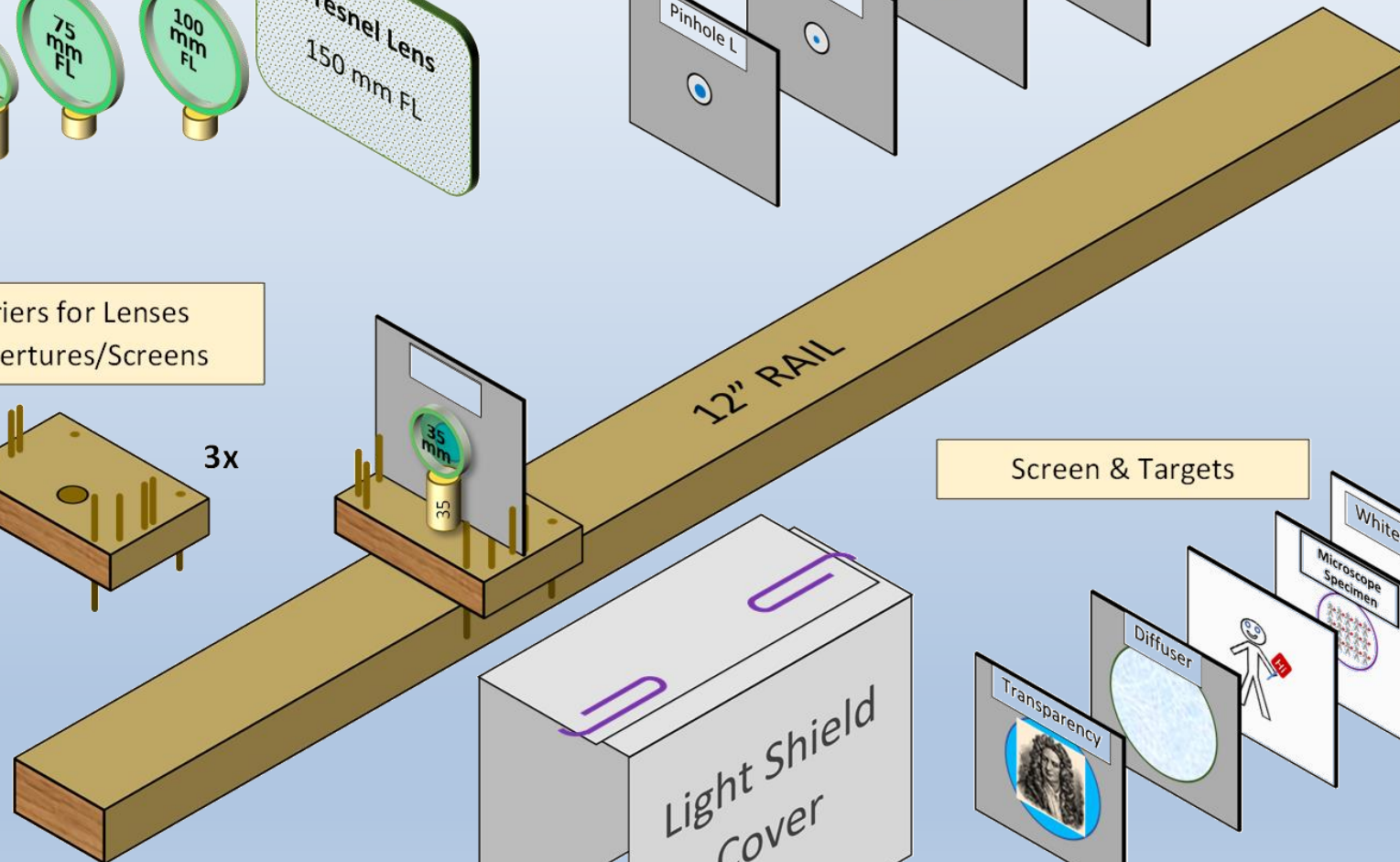
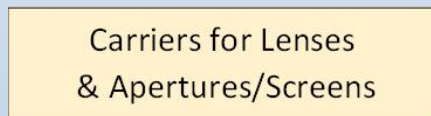
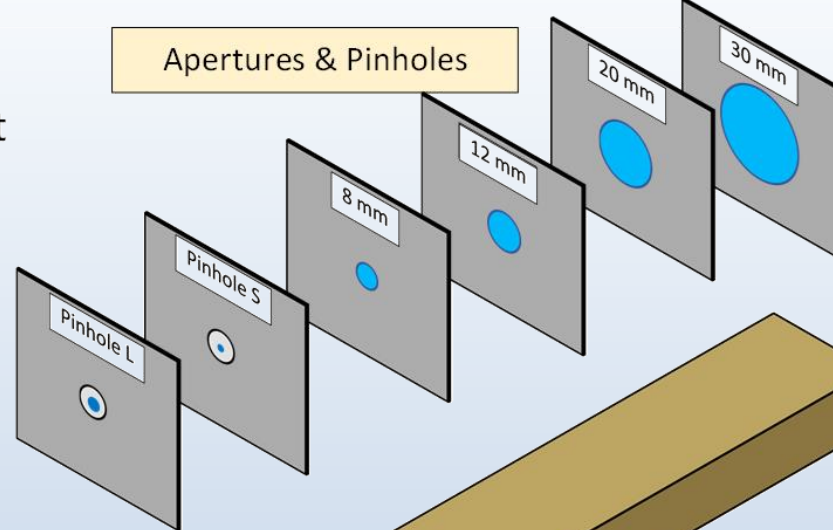
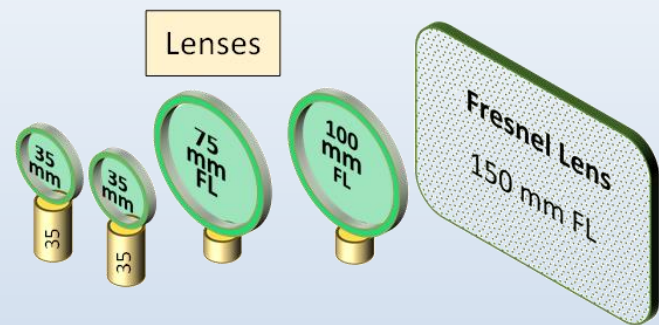

OLLI-OP

Your Kit contains everything you need to test a Burning Glass:

- *Fresnel Lens*
- *Target Ship*
- *Holder Clips*

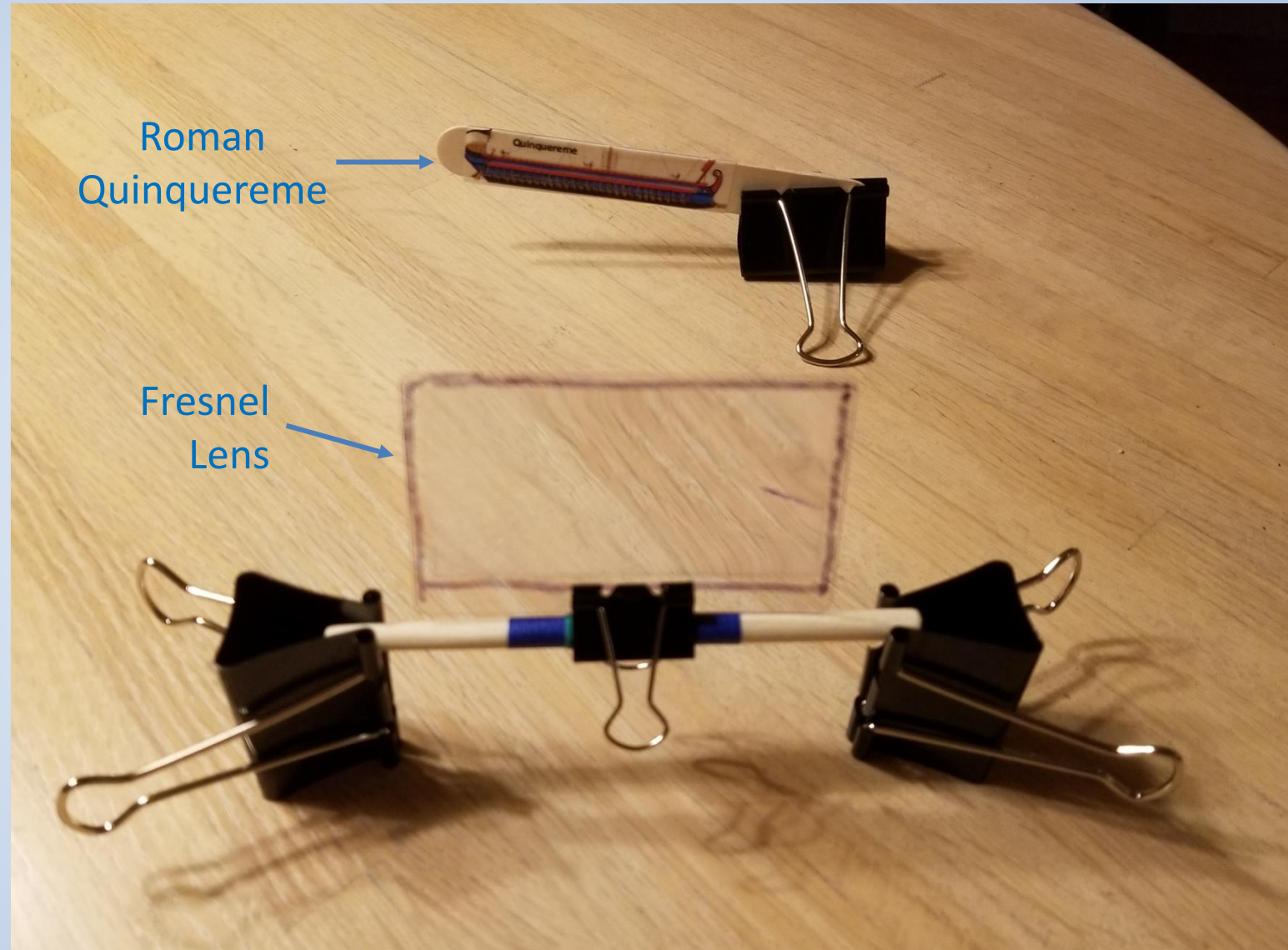

OLLI-OP



Roman
Quinquereme

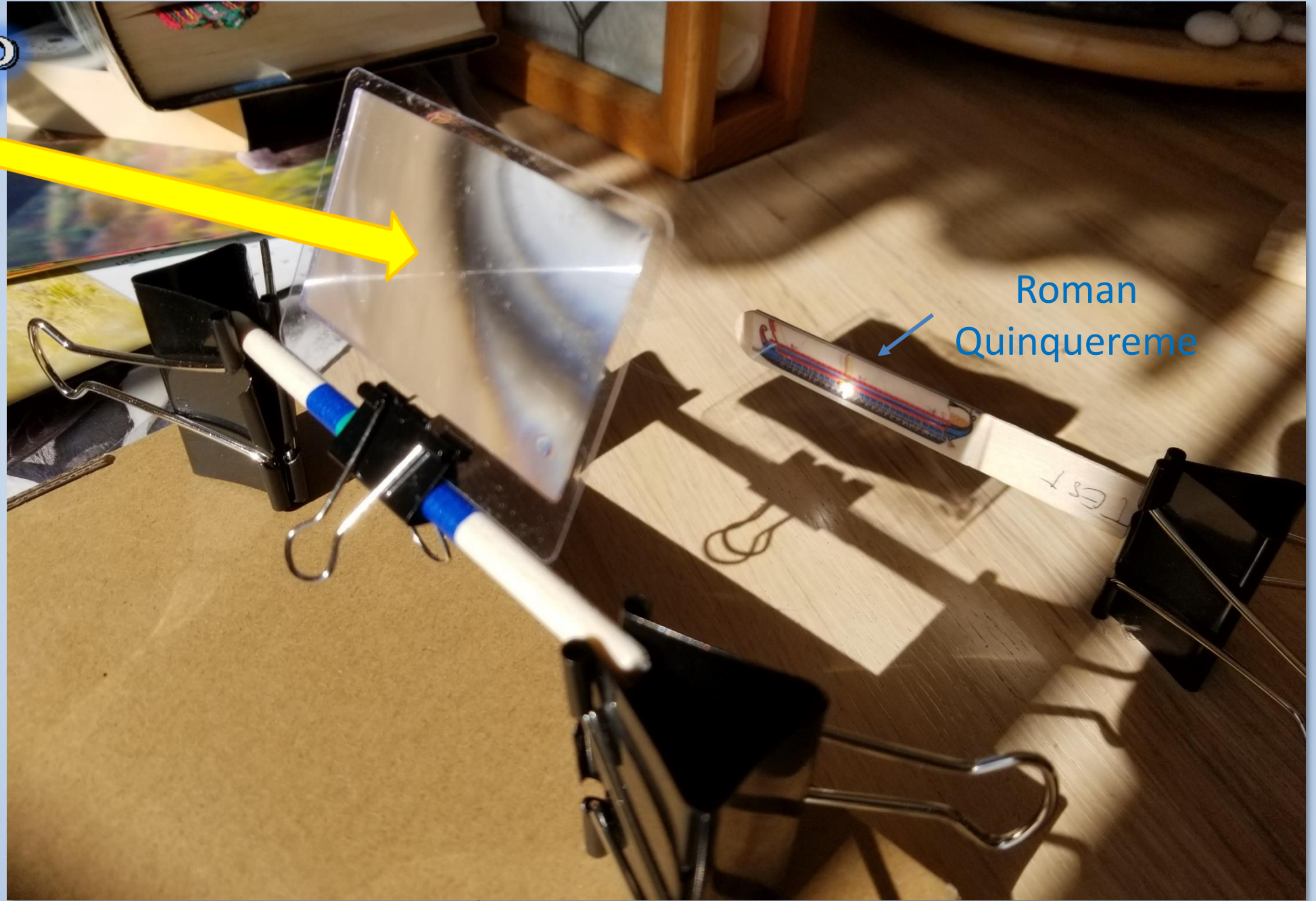

OLLI-OP

Camera Obscura (Pinhole Camera)

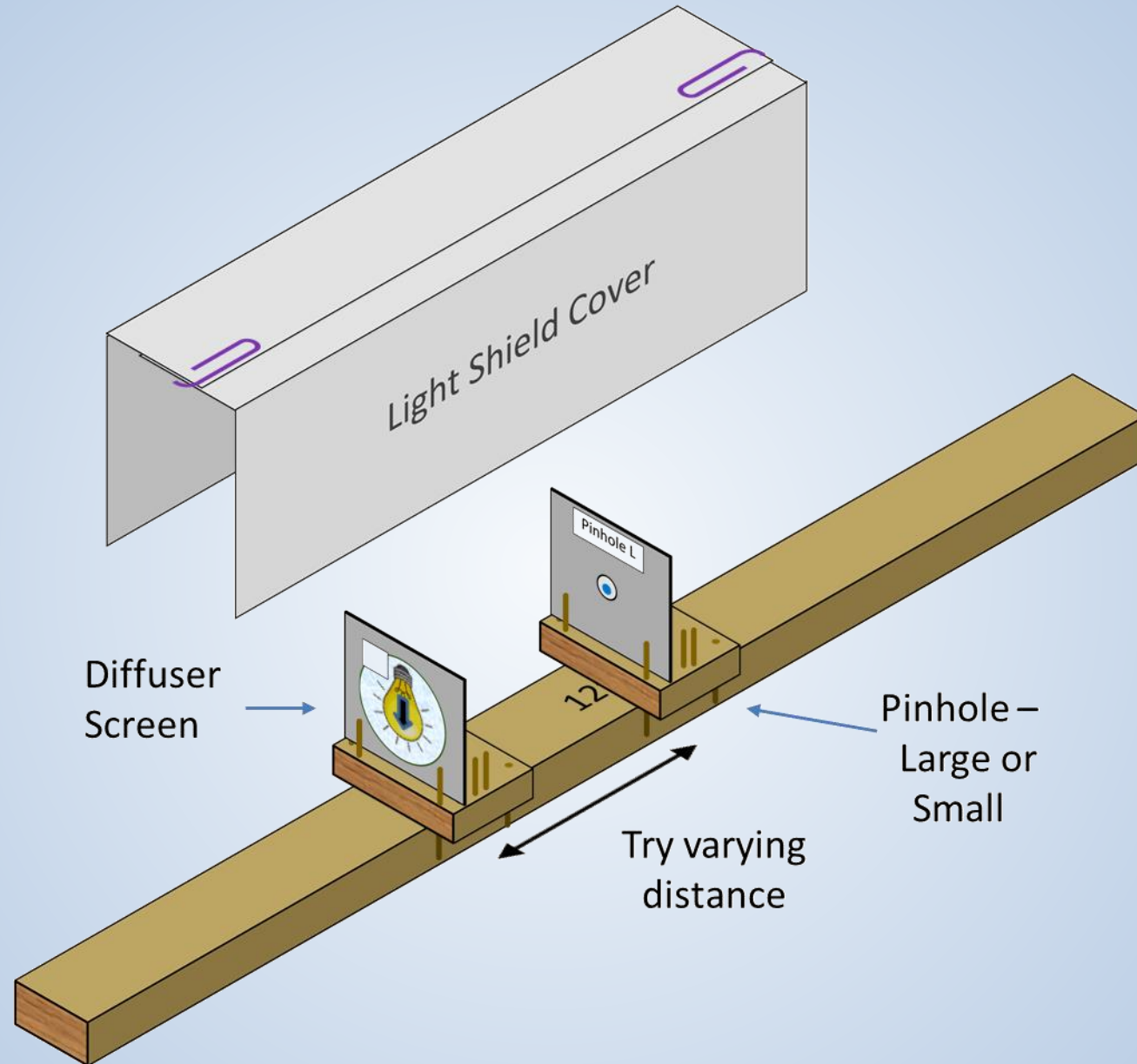

OLLI-OP

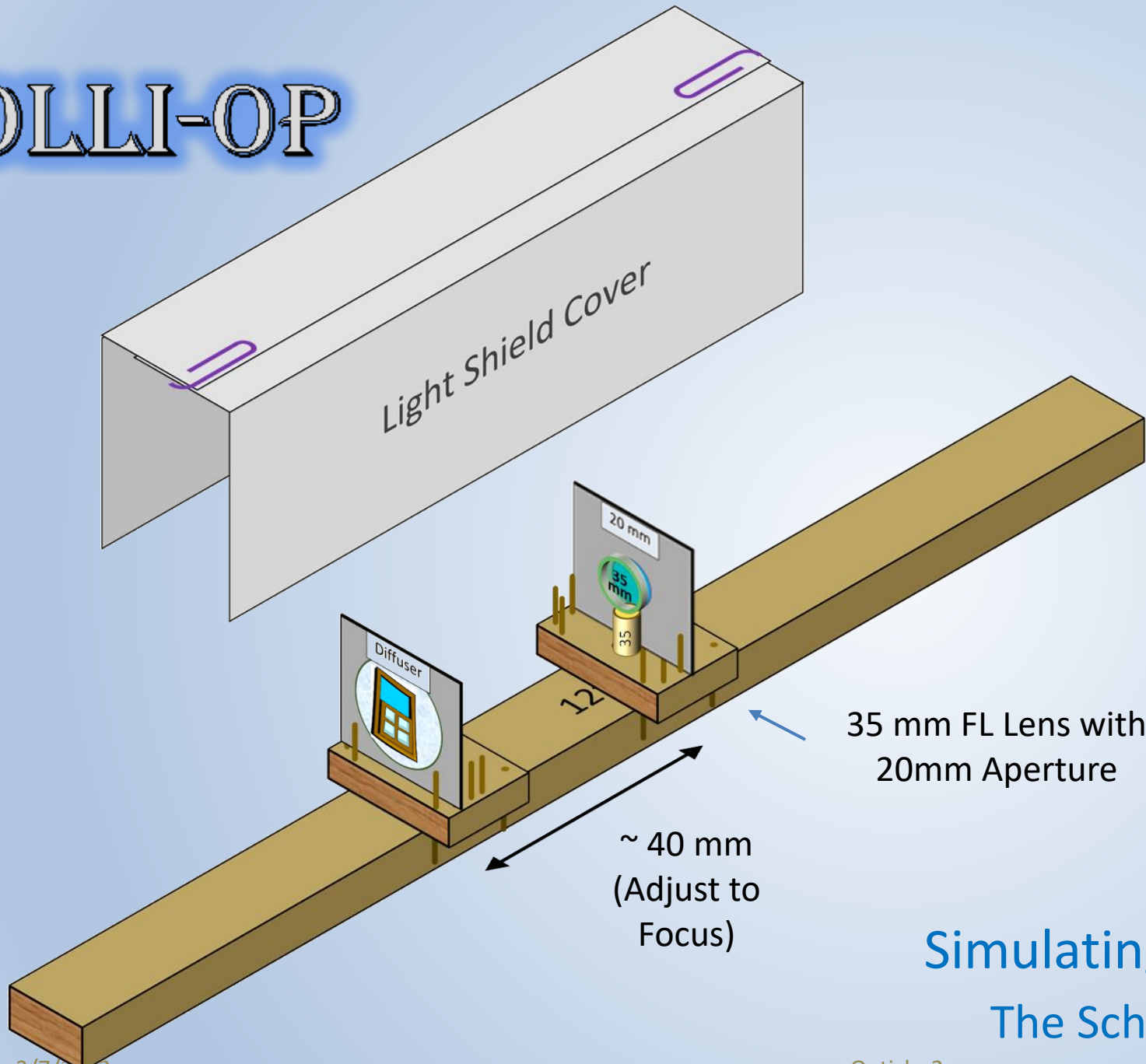

35 mm FL Lens with
20mm Aperture

~ 40 mm
(Adjust to
Focus)

Simulating the Eye: The Scheiner Experiment



OLLI-OP

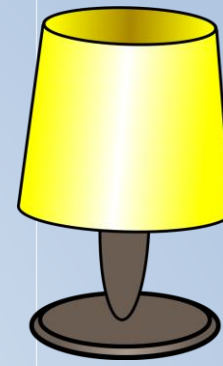
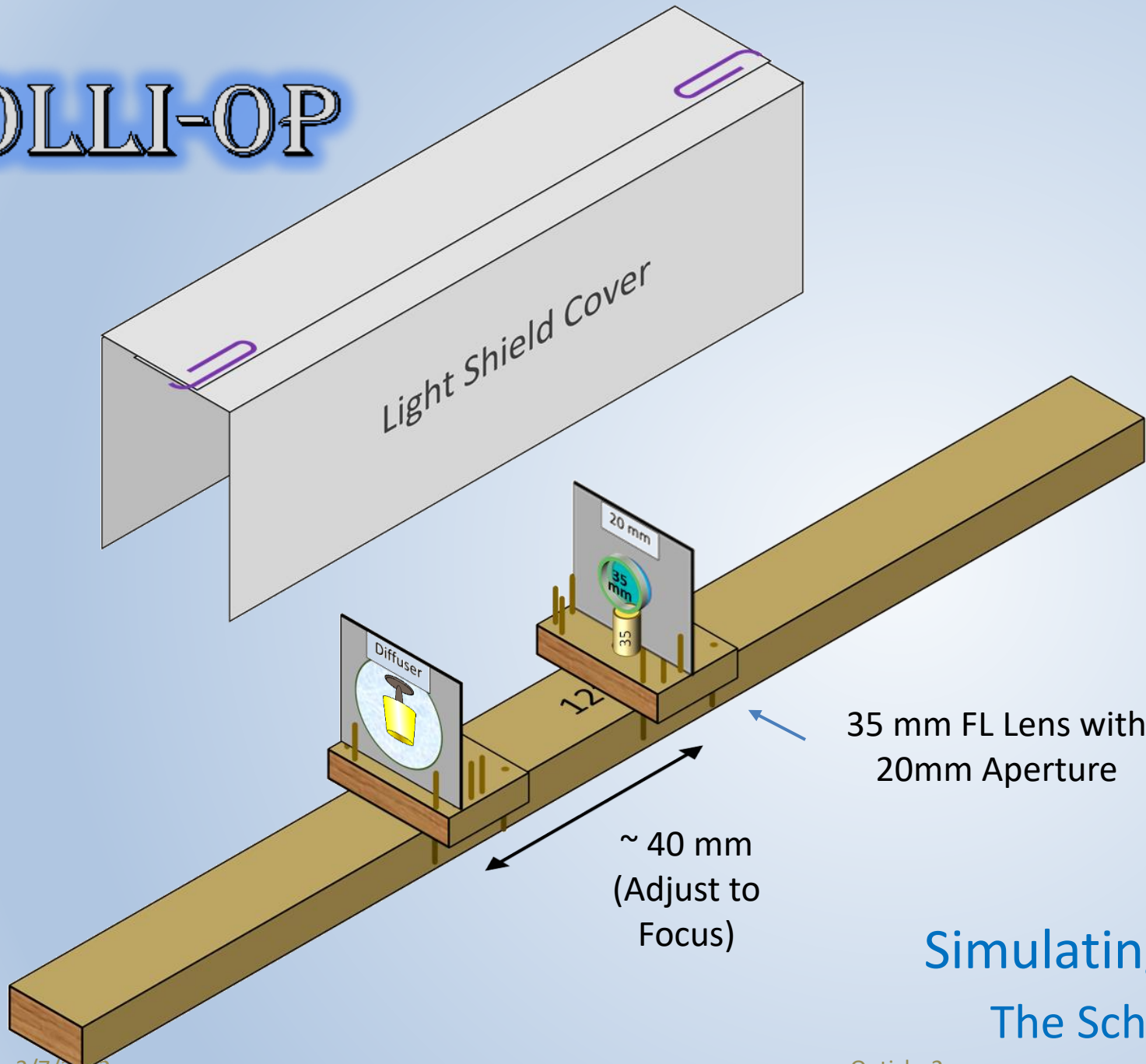

At night, a bright light fixture makes a good Object

Simulating the Eye: The Scheiner Experiment



OLL LOP

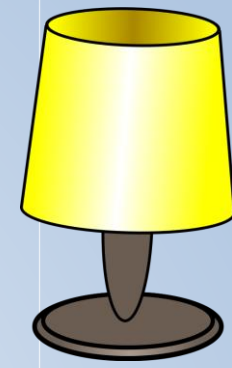
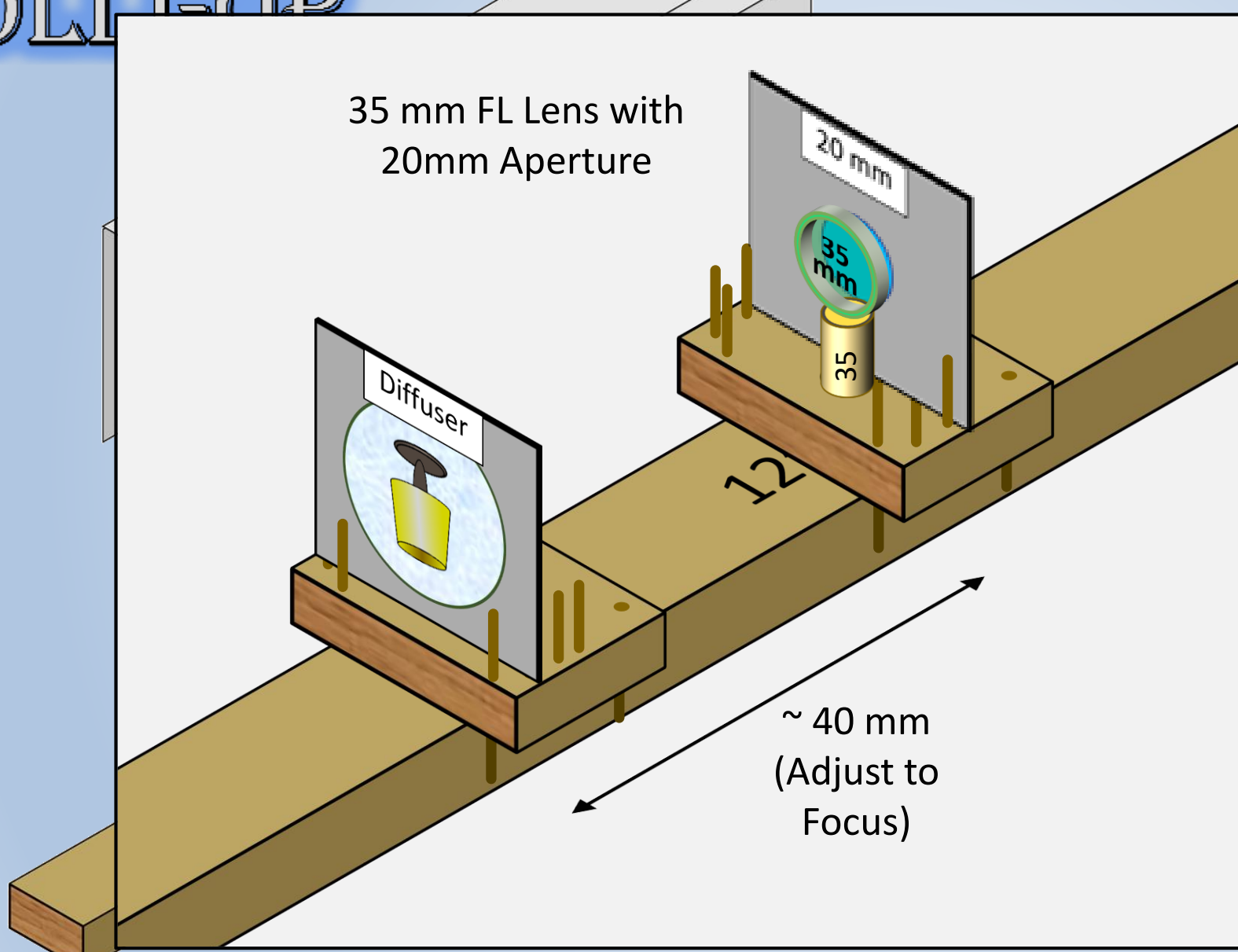

At night, a bright light fixture makes a good Object

Simulating the Eye: The Scheiner Experiment



OLLI-OP

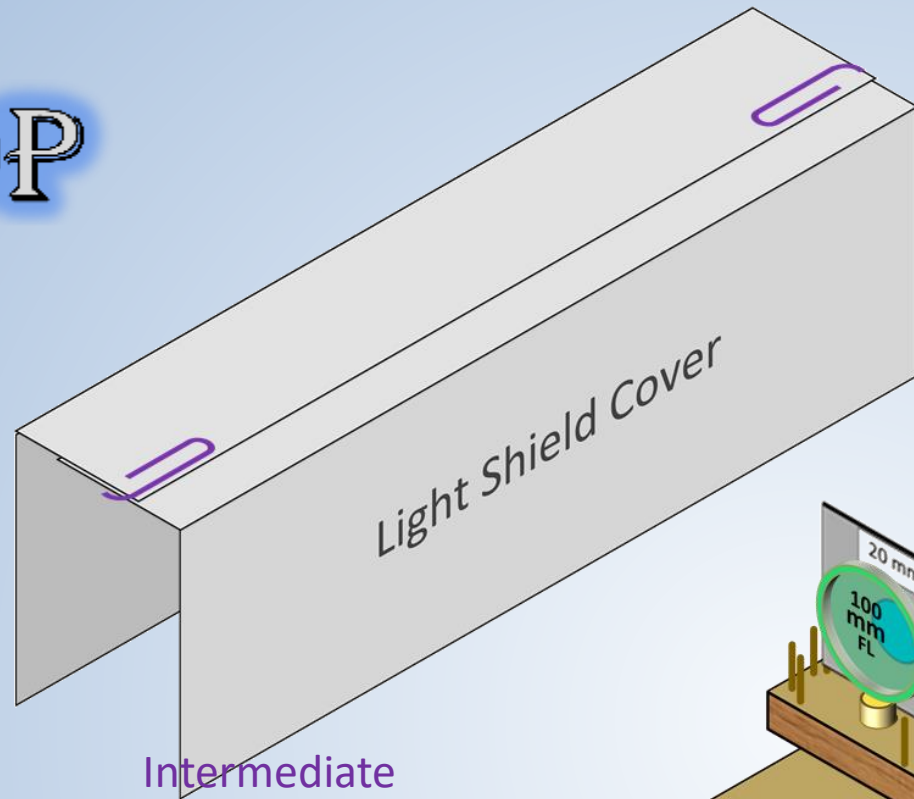

35 mm FL Eye Lens
with 12 mm
Aperture

Intermediate
Real Image

100 mm FL Objective
with 20mm Aperture

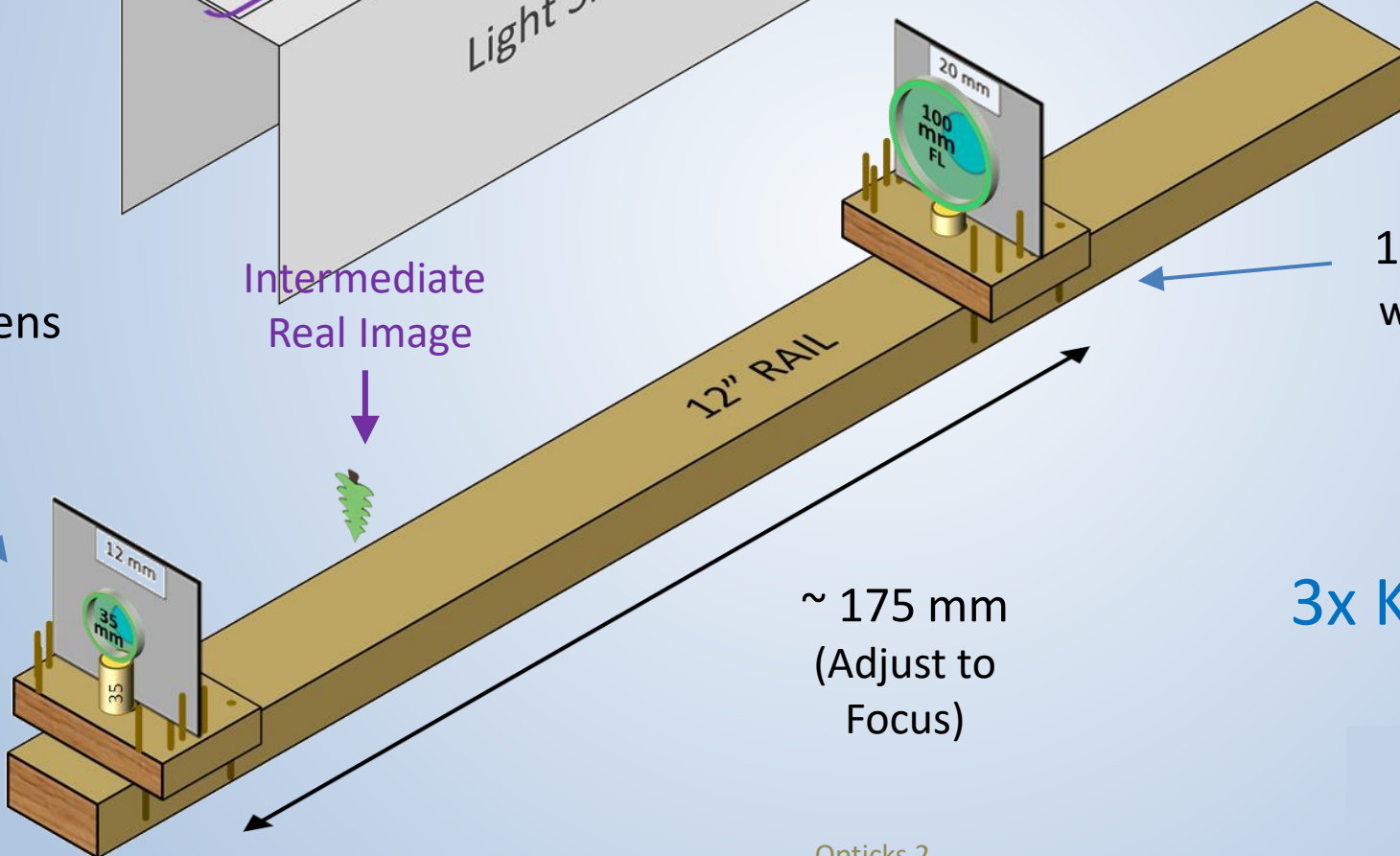

~ 175 mm
(Adjust to
Focus)

3x Keplerian Telescope



OLLI-OP

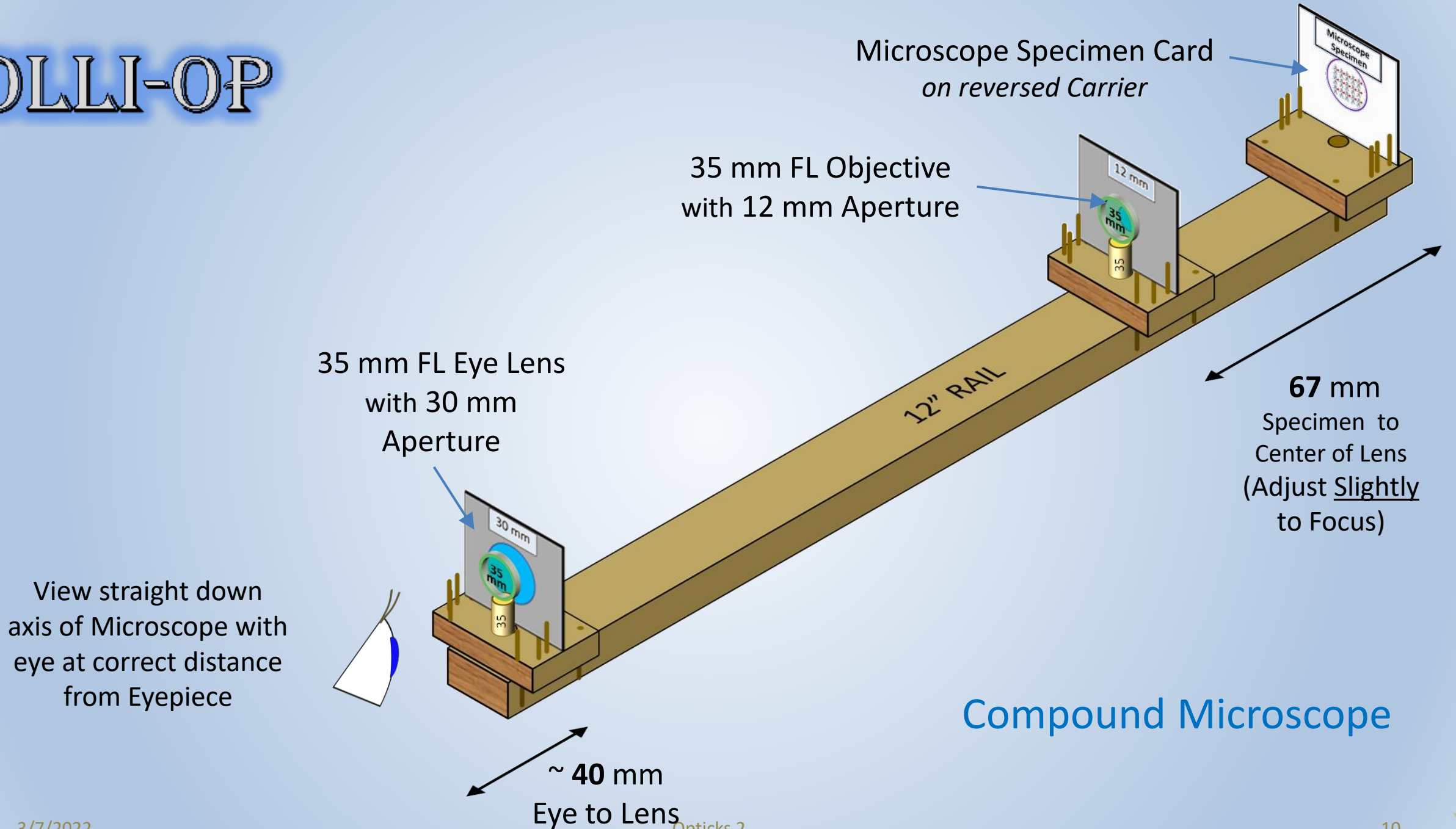

OLLI-OP

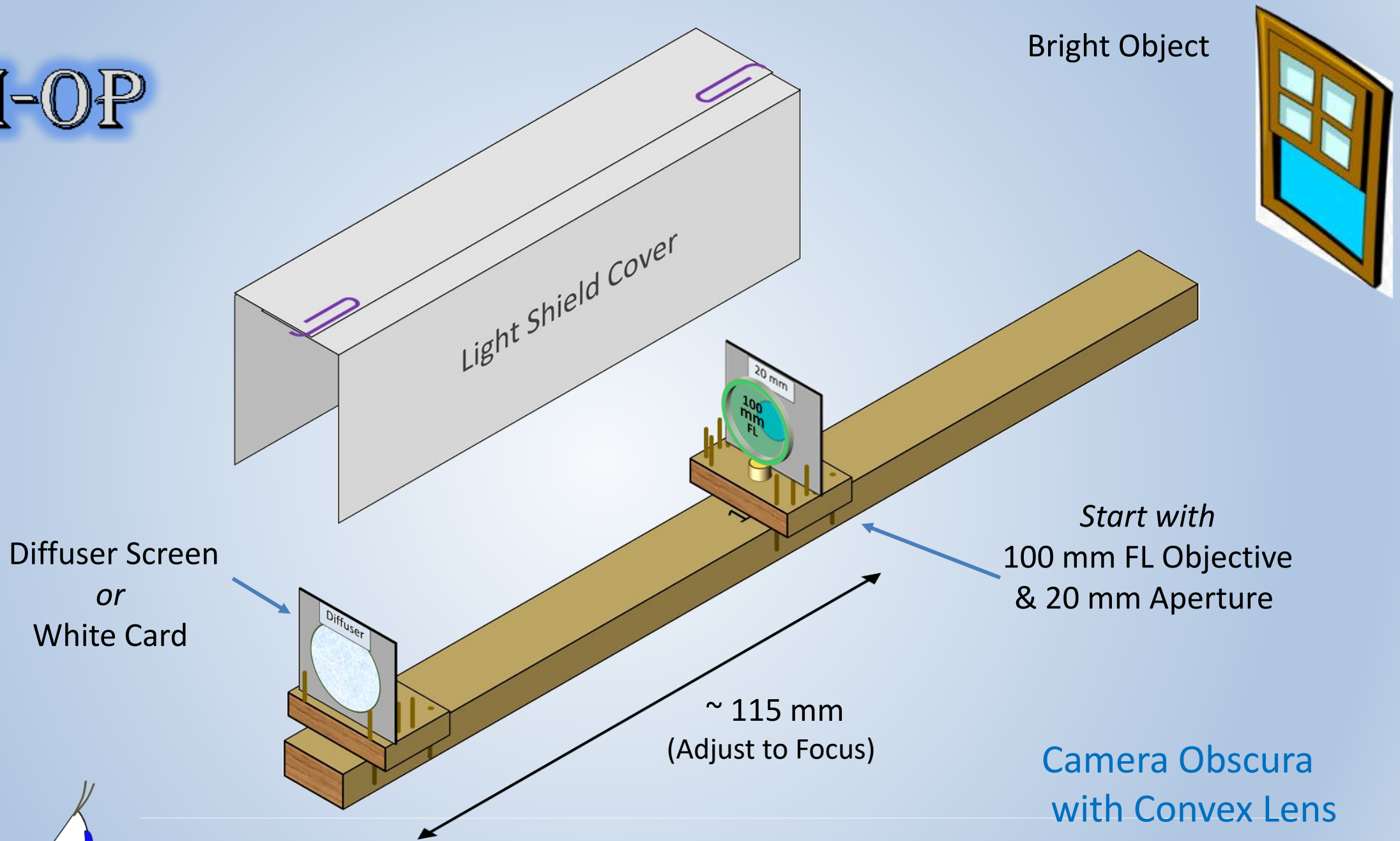

OLLI-OP

LANTERNA

MAGICA

HUYGENS

